



TECHNICAL DATA SHEET

Bulletin : BAA: D0027-1
 Effective : JULY 25, 2006
 Supercedes : BAA: D0027-0
 dated Nov.01, 2003

BRY-AIR (ASIA) PVT. LTD.

20, Rajpur Road, Delhi 110054

PHONE : 91-11-23906666 FAX: 91-11-23906600

E-MAIL: enquire@pahwa.com, Web site: www.bryair.com

ECO-SCRUB AIR & GAS PURIFICATION SYSTEMS

BPU-T SERIES

THIN BED

BRY AIR INTRODUCES BPU-T-SERIES THIN BED AIR AND GAS PURIFIERS WITH FOLLOWING SALIENT FEATURES

High efficiency and reliability

- Self contained recirculatory unit upto 3-Stages, offered, both in Horizontal and Vertical configuration
- Removes both organic and inorganic contaminants from the air and supplies air free of contaminant gases.
- Robust structural steel frame construction, CNC fabricated powder coated units
- Insulated units with double skin walls and panels (Optional)
- Pre filter, 2" deep, 30% efficiency, ASHRAE standard filtration.
- After-filter, 2" deep, 30% efficiency, ASHRAE standard filtration (Optional).
- Fine filter, 6" deep, 95% efficiency, ASHRAE standard filtration.
- Microprocessor based Digital Control Card (Optional)

Easy to operate

- Suitable for continuous operation.
- Manual switch for operating the system.

Easy to install

- Versatile, easy to package and handle.
- Small footprint, low volume/weight per CMH

Easy to maintain

- Quick and easy to service
- Easy Eco-Scrub media replacement.
- Easy, tool free access to all major components.
- Quick serviceability and maintenance free operation

Options

- Air / gas flow control through Variable Frequency Drive (VFD)
- Stainless steel construction
- Volume control damper for control air flow (optional).

Air and Gas Purification Units - BPU-T Series

MODEL**	Air Flow		ESP (Pa)	MOTOR KW	POWER * REQD. VAC/Φ/Hz	APPROX. WEIGHT (Kg)	
	CMH	CFM				TH ¹	TV ²
BPU-500-T-1	850	500	250	0.75	415/3/50	210	175
BPU-500-T-2	850	500	250	0.75	415/3/50	245	208
BPU-500-T-3	850	500	250	1.12	415/3/50	270	229
BPU-1000-T-1	1700	1000	250	1.12	415/3/50	240	204
BPU-1000-T-2	1700	1000	250	1.49	415/3/50	270	229
BPU-1000-T-3	1700	1000	250	1.49	415/3/50	300	255
BPU-1500-T-1	2550	1500	250	2.24	415/3/50	320	272
BPU-1500-T-2	2550	1500	250	2.24	415/3/50	375	319
BPU-1500-T-3	2550	1500	250	3.73	415/3/50	440	374
BPU-2000-T-1	3400	2000	250	3.73	415/3/50	375	319
BPU-2000-T-2	3400	2000	250	3.73	415/3/50	445	378
BPU-2000-T-3	3400	2000	250	3.73	415/3/50	570	484

* Note:-

* Units suitable for other systems voltages and frequencies viz. 200/220/240/380/ 440/ 460 VAC, 3Ph, 50/60, also available on request.

** Data common for both, Horizontal and Vertical unit.

1. Thin Bed (Horizontal) units
2. Thin Bed (Vertical) units.



DIMENSIONAL DATA & DUCT CONNECTION (HORIZONTAL UNITS)

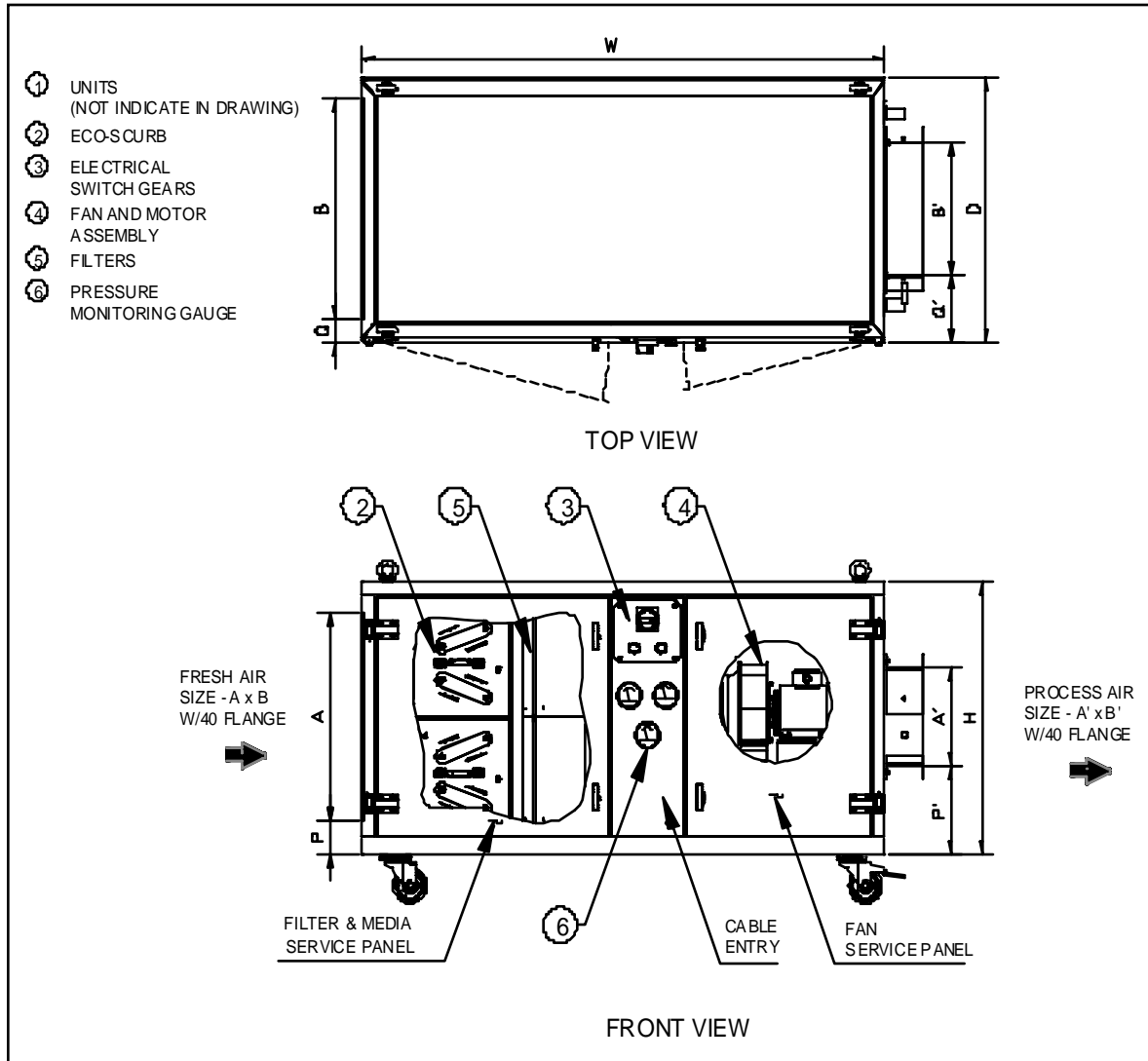

MODEL	UNIT DIMENSIONS			DUCT CONNECTIONS							
				FRESH AIR				SUPPLY AIR			
	H	D	W	A	B	P	Q	A'	B'	P'	Q'
BPU-500-TH-1	760	735	1575	275	610	250	62	275	370	248	181
BPU-500-TH-2	760	735	1900	275	610	250	62	275	370	248	181
BPU-500-TH-3	760	735	2225	275	610	250	62	275	370	248	181
BPU-1000-TH-1	760	735	1575	570	610	100	62	275	370	248	181
BPU-1000-TH-2	760	735	1900	570	610	100	62	275	370	248	181
BPU-1000-TH-3	760	735	2225	570	610	100	62	275	370	248	181
BPU-1500-TH-1	1070	735	1575	880	610	100	62	275	370	248	181
BPU-1500-TH-2	1070	735	1900	880	610	100	62	275	370	248	181
BPU-1500-TH-3	1070	735	2225	880	610	100	62	275	370	248	181
BPU-2000-TH-1	1370	735	1575	1200	610	100	62	275	610	248	62
BPU-2000-TH-2	1370	735	1900	1200	610	100	62	275	610	248	62
BPU-2000-TH-3	1370	735	2225	1200	610	100	62	275	610	248	62

ALL DIMENSIONS ARE IN MILLIMETER



DIMENSIONAL DATA & DUCT CONNECTION (VERTICAL UNITS)

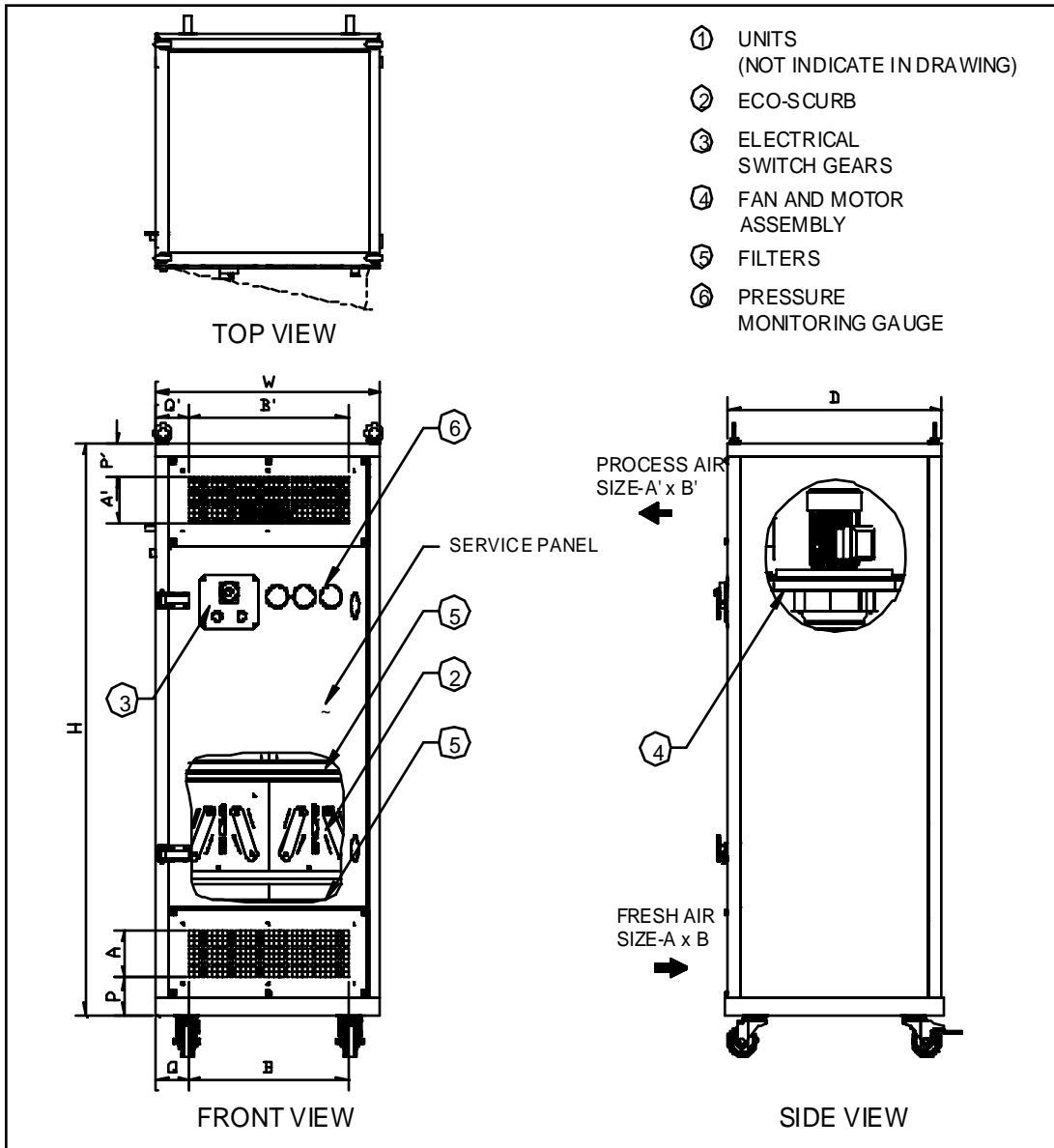

MODEL	UNIT DIMENSIONS			DUCT CONNECTIONS							
				FRESH AIR				SUPPLY AIR			
	H	D	W	A	B	P	Q	A'	B'	P'	Q'
BPU-500-TV-1	1790	710	746	190	570	85	90	190	570	85	90
BPU-500-TV-2	2100	710	746	190	570	85	90	190	570	85	90
BPU-500-TV-3	2450	710	746	190	570	85	90	190	570	85	90
BPU-1000-TV-1	1790	710	746	190	570	85	90	190	570	85	90
BPU-1000-TV-2	2100	710	746	190	570	85	90	190	570	85	90
BPU-1000-TV-3	2450	710	746	190	570	85	90	190	570	85	90
BPU-1500-TV-1	1790	710	1055	190	570	85	90	190	570	85	90
BPU-1500-TV-2	2100	710	1055	190	570	85	90	190	570	85	90
BPU-1500-TV-3	2450	710	1055	190	570	85	90	190	570	85	90
BPU-2000-TV-1	1790	710	1490	190	570	85	90	190	570	85	90
BPU-2000-TV-2	2100	710	1490	190	570	85	90	190	570	85	90
BPU-2000-TV-3	2450	710	1490	190	570	85	90	190	570	85	90

ALL DIMENSIONS ARE IN MILLIMETER



GUIDELINES TO SELECT BRY-AIR ECO-SCRUB UNITS

ECO-SCRUB MEDIA LIFE ESTIMATION

In order to estimate EcoScrub media life, use the formulae :

$$N = 10.72 \times \frac{ACFM}{NCFM} \times \frac{PPM \times MW}{F_1 \times F_2}$$

- N = Number of stages of EcoScrub
- ACFM = Actual air flow, the EcoScrub is proposed to be adjusted to, for optimum utilization of media (in CFM).
- NCFM = Nominal air flow of the EcoScrub model selected (in CFM)
- PPM = Concentration of the contaminant in air (in PPM)
- MW = Molecular Weight of the contaminant.
- F₁ = Useful capacity factor of adsorbent (media) –Table 1
- F₂ = Bulk density factor of adsorbent (media) – Table 1
- 10.72 = Constant

Table 1 : Useful Adsorbent Capacity and Bulk Density Factors of Contaminants

Contaminant	Factors	Adsorbent (BRYSORB Media)					
		502	508	515	520	525	502 B
Sulphur dioxide	F ₁	4	6	6			
	F ₂	50	50	45			
Hydrogen sulphide	F ₁	8	14	14			
	F ₂	50	50	45			
Chlorine	F ₁			8	10		
	F ₂			45	30		
Ammonia	F ₁					7	
	F ₂					40	
Nitric acid	F ₁	3	4				
	F ₂	50	50				
Nitrogen dioxide	F ₁				7		
	F ₂				30		
Formaldehyde	F ₁	1.5	2.5				
	F ₂	50	50				
Carbon disulphide	F ₁				7.5		
	F ₂				30		
Methyl mercaptan	F ₁						11
	F ₂						40
Toluene	F ₁				20		
	F ₂				30		
Isopropyl alcohol	F ₁				11		21
	F ₂				30		40
Trichloroethane	F ₁				20		
	F ₂				30		
Ethylene	F ₁	1	1.5				
	F ₂	50	50				
Acetone	F ₁						12
	F ₂						40

2. If the value of N works out to be 1 or less than 1, then a 1-Stage unit can be safely offered for media life of approx. 12 months. In case, the value of N is 1.5 and still a 1-Stage unit is offered, then the media life is reduced to 8 months – 12 / 1.5 = 8 months
3. If EcoScrub media selected for the second / next contaminant is different from one selected for the first contaminant, a 2-Stage unit will be selected with media life calculated out separately for each media as expanded above.
4. If EcoScrub media selected for two or more contaminants is same, the number of beds, worked out for individual contaminants, can be summed up for combined selection of media.
5. Number of Stages of ECO-SCRUB unit should not exceed 3 (three). If, however, the number of stages works out to be more than 3, non-standard unit option. (with up to 4 (four) Stages) is available. Check with Engg. Department of BRY-AIR (ASIA) PVT LTD for guidance, if so happens.

STEPS TO SELECT “THIN BED” ECO-SCRUB

Single adsorbent based applications

- a. If the number of stages, on the basis of above selection procedure works out to be less than 0.25, select the corresponding Thin Bed 1-Stage model of Eco-Scrub.
- b. If the number of stages, on the basis of above selection procedure works out to be more than 0.25 but less than 0.5, select the corresponding Thin Bed 2-Stage model of Eco-Scrub.
- c. If the number of stages, on the basis of above selection procedure works out to be more than 0.5 but less than 0.75, select the corresponding Thin Bed 3-Stage model of Eco-Scrub.

Two / multiple adsorbent based applications

- a. If the number of stages for each of the adsorbent, selected on the basis of above selection procedure, works out to less than 0.25, select the corresponding Thin Bed 2-Stage or 3-Stage model of Eco-Scrub, depending on the number of adsorbents selected.
- b. If the number of stages for each of the adsorbent, selected on the basis of above selection procedure, works out to less than 0.25 for one adsorbent and, more than 0.25 but less than 0.5 for second adsorbent, select a Thin Bed 3-Stage model of Eco-Scrub with one bed of the unit charged with former and the remaining two beds charged with the later adsorbent.

STEPS TO SELECT “DEEP BED” ECO-SCRUB

1. Refer Table 1' to first determine the best media to counter the contaminant (s).

