

BRY-AIR (ASIA) PVT. LTD.

20, RAJPUR ROAD, DELHI - 110054 (INDIA)
 PHONE : 91-11-23906666 FAX: 91-11-3906600
 E-MAIL: enquire@pahwa.com, Web site: www.bryair.com

INDUSTRIAL DEHUMIDIFIER

FLi - SERIES

FLi WITH HIGH PERFORMANCE, **ECGDry** METAL SILICATE FLUTED
 DESICCANT SYNTHESISED ROTOR

FEATURE HIGHLIGHTS

High efficiency and reliability

- * **CE** Certified as per standard EN ISO12100-1:2003, EN ISO12100-2:2003, EN60204-1:2006+A1 2009
- * Meeting essential requirements of European directives Low Voltage directive 2006/95/EC machine directive 2006/42/EC, EMC : 2004/108/EC
- * A totally self contained unit.
- * Robust stainless steel frame with double skin construction, internal GI sheet.
- * CNC fabricated with industrial grade coating.
- * High moisture removal.
- * EU-3 grade leak tight filters for Air intakes.
- * Multiple choice of reactivation heat source:- electrical, steam, thermic fluid, direct/indirect fired gas
- * In-bolt process by-pass for custom designing of process air flow or process temperature control
- * Easy addition of pre/after cooler, higher grade filter
- * Rotor incorporates robust internal structure with perimeter flange for industrial quality and durability.
- * Rotor perimeter flange extend media and seal life
- * Rotor is non-flammable with organic < 2%.
- * Edge hard face coating on rotor edge ensures long life and good sealing for media and seals.
- * Process and reactivation air flow sectors are insulated
- * Unique PTFE bonded bulb seal design; minimized air leakage

Easy to operate

- * Suitable for continuous operation
- * Auto / manual selector switch.
- * Volume control dampers for both (P&R) air flow

Easy to install

- * Versatile, easy to package and handle
- * Small footprints; low volume/weight per CMH

Easy to maintenance

- * Rotor is water washable
- * Quick serviceability and maintenance free-operation

Options

- * Humidity control by humidistat on/off
- * Stainless steel construction
- * Bry-Smart Controller

INDUSTRIAL DEHUMIDIFIER - FLi ... SPECIFICATION

MODEL	PROCESS AIR FLOW CMH	PROCESS ESP (Pa.)	PROCESS MOTOR KW	REACT AIR FLOW CMH	REACT	REACT MOTOR KW	REACT HEATER KW	POWER* REQD.	APPROX. WEIGHT (Kg)
					ESP (Pa.)				
FLi 2500	2500	300	1.5	833	250	0.75	26	415 / 3 / 50	500
FLi 3000	3000	300	1.5	1000	250	0.75	33	415 / 3 / 50	500
FLi 4200	4200	300	2.2	1400	250	1.1	46	415 / 3 / 50	550
FLi 5000	5000	300	3.7	1667	250	1.1	53	415 / 3 / 50	550
FLi 6200	6200	300	2.2	2067	250	1.5	64	415 / 3 / 50	950
FLi 7300	7300	300	3.7	2433	250	1.5	76	415 / 3 / 50	950
FLi 8000	8000	300	3.7	2667	250	1.5	85	415 / 3 / 50	1025
FLi 9000	9000	300	3.7	3000	250	2.2	96	415 / 3 / 50	1050
FLi 10500	10500	300	3.7	3500	250	2.2	114	415 / 3 / 50	1050

* Note:- Other voltage available are 200/220/240/415/440/460 VAC, 3Ph, 50/60 Hz

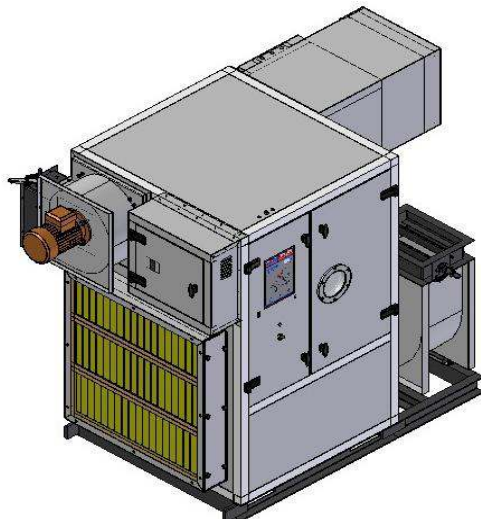

ALL DATA SUBJECT TO CHANGE WITHOUT NOTICE



DIMENSIONAL DATA & DUCT CONNECTION

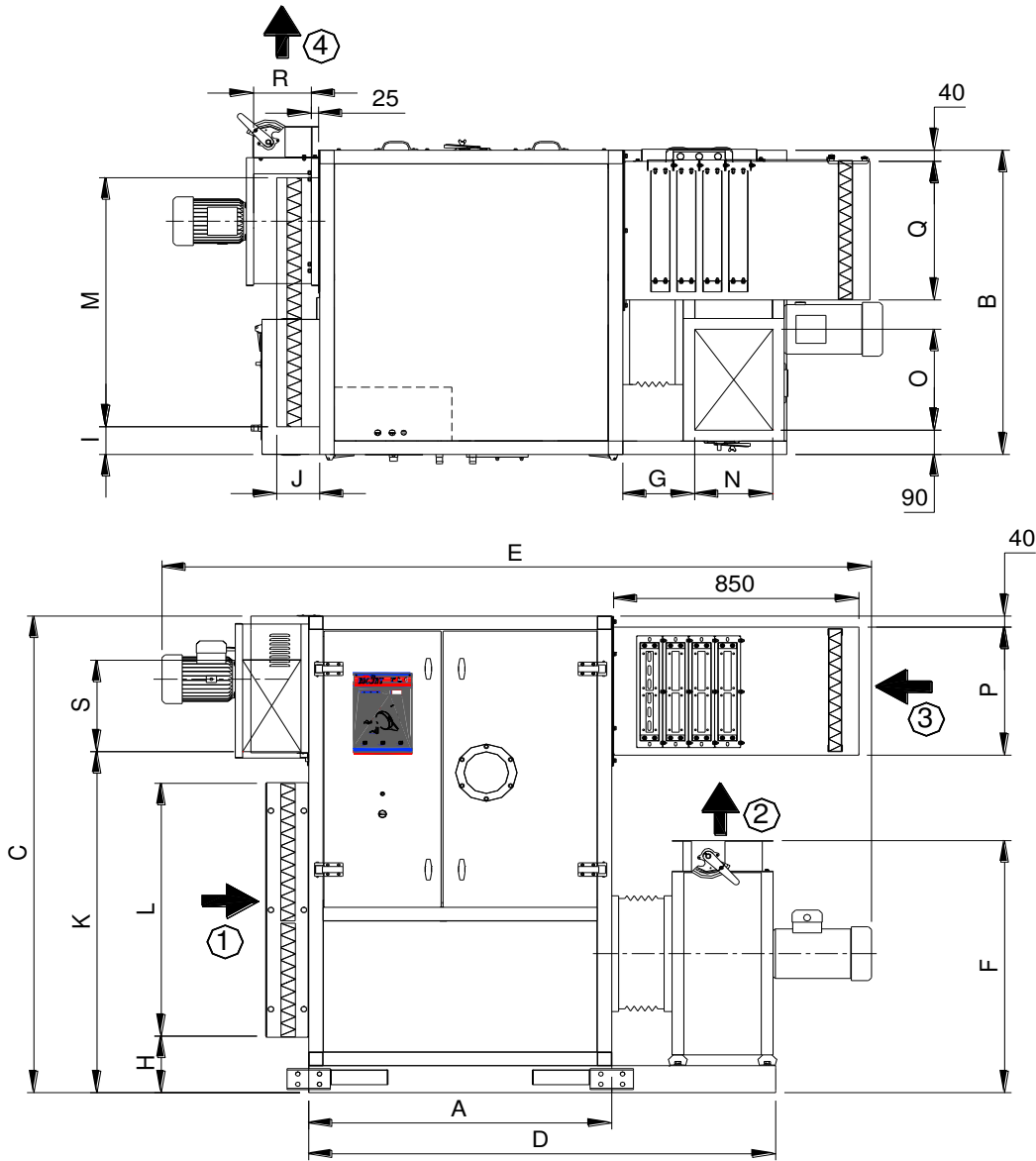

MODEL	UNIT DIMENSION DATA												PROCESS DUCT CONNECTION (mm)				REACTIVATION DUCT CONNECTION (mm)			
													INLET (1)		OUTLET (2)		INLET (3)		OUTLET (4)	
	A	B	C	D	E	F	G	H	I	J	K	L	M	N	O	P	Q	R	S	
FLi 2500	1050	1220	1770	1594	2600	876	249	210	103	150	1324	939	925	244	340	476	515	150	160	
FLi 3000	1050	1220	1770	1594	2600	876	249	210	103	150	1324	939	925	244	340	476	515	150	160	
FLi 4200	1050	1220	1770	1618	2600	936	249	210	103	150	1266	939	925	270	375	476	515	200	340	
FLi 5000	1050	1220	1770	1618	2600	936	249	210	103	150	1266	939	925	270	375	476	515	200	340	
FLi 6200	1050	1400	1950	1740	2600	1191	249	251	138	150	1448	1038	1030	390	552	476	617	200	340	
FLi 7300	1050	1400	1950	1740	2600	1191	249	251	138	150	1448	1038	1030	390	552	476	617	200	340	
FLi 8000	1050	1600	2150	1788	2730	1291	258	169	138	150	1481	1248	1235	438	614	631	619	268	375	
FLi 9000	1050	1600	2150	1788	2730	1291	258	169	138	150	1481	1248	1235	438	614	631	619	268	375	
FLi 10500	1050	1600	2150	1788	2730	1291	258	169	138	150	1481	1248	1235	438	614	631	619	268	375	

ALL DATA SUBJECT TO CHANGE WITHOUT NOTICE



PERFORMANCE CHART FLi -SERIES

Performance charts are for nominal process airflow within the operating range each FLi Series and assumes XPI = XRI. Please consult bry-air for other specific condition.

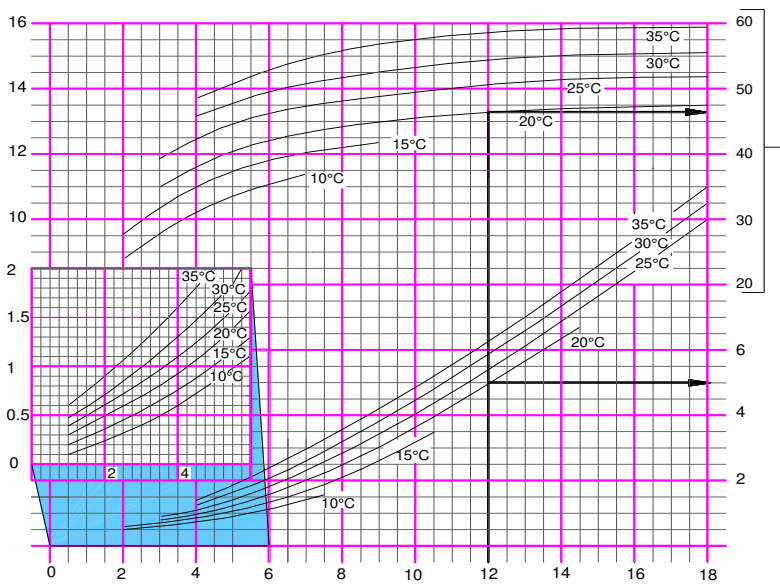

PROCESS INLET AIR MOISTURE CONTENT pi(g/kg)

w PI = 12g/kg,
T PI. = 20°C

w PO = 5g/kg,
T PO. = 46.5°C

PRESSURE DROP CHART

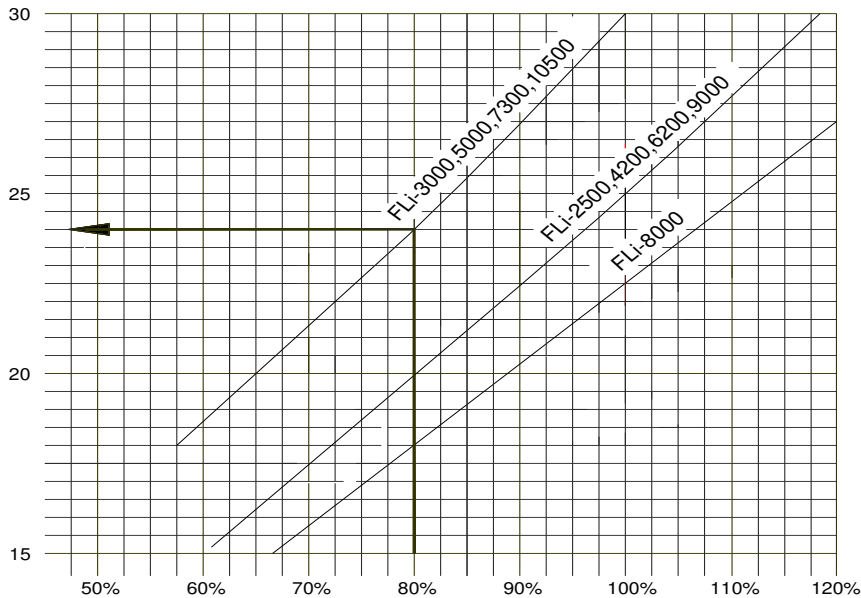

% NOMINAL AIR FLOW

ime = 4000 m³/h
%
24 mm w.c.

ALL DATA SUBJECT TO CHANGE WITHOUT NOTICE



PERFORMANCE CHART FLi-SERIES

The fan performance curve are for inlet conditions at 20°C, density 1.2kg/m³

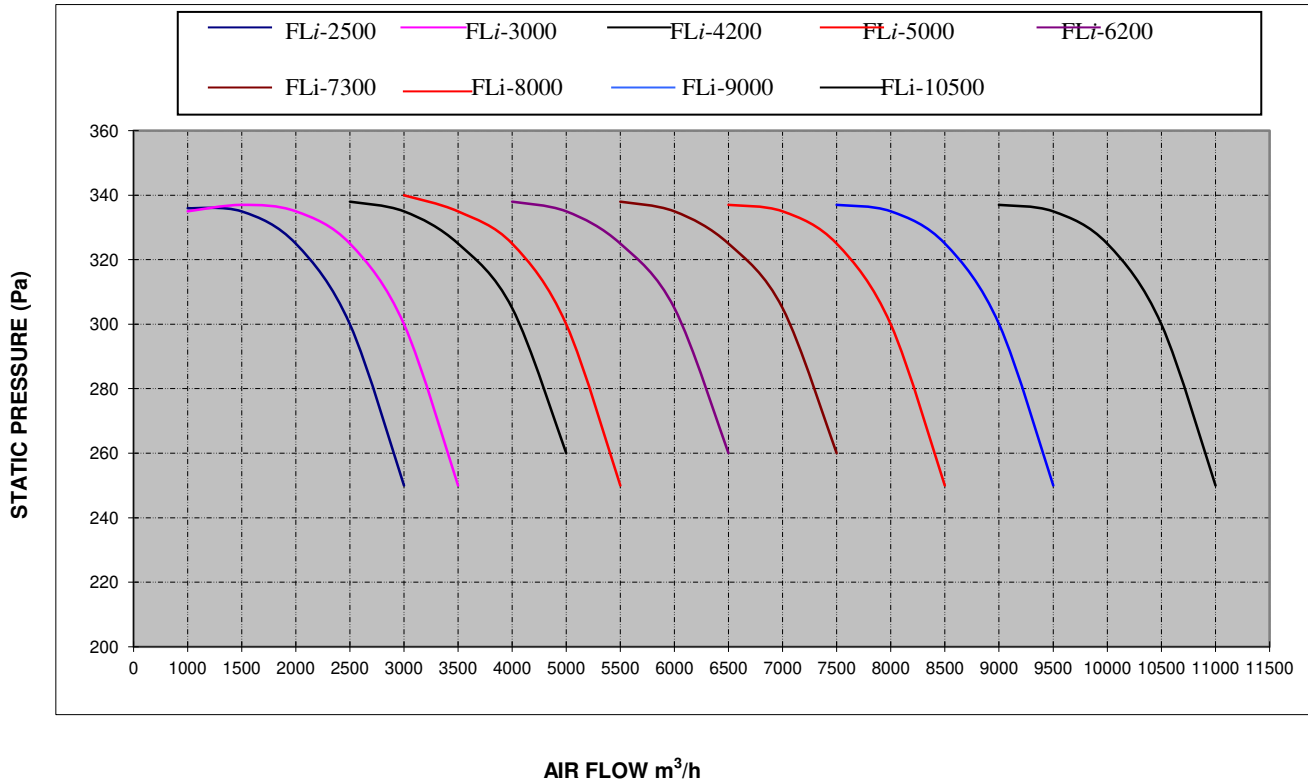

FEATURE OVERVIEW

	Items	Standard	Optional
Rotor :	High performance metal silicate	√	
	High performance metal silicate (High RH)		√
	High performance molecular sieve (Low RH)		√
Process :	High capacity synthetic nonwoven mesh filter	√	
	External box fitted with EU5 / filter		√
	External box fitted with EU7 / filter		√
	Higher static fan		√
	Process pre-cooler /after cooler.		√
Reactivation :	High capacity metallic mesh filter	√	
	External box fitted with EU5 / filter		√
	External box fitted with EU7 / filter		√
	Higher static fan		√
Energy :	Electric or steam reactivation	√	
	External box fitted with gas reactivation		√
Construction :	Cold drawn steel SS frame with GI internal screen & cold draw	√	
	Stainless steel		√
Control :	Single stage On/Off humidstat		√
	Proportional humidity sensor with SSR		√
	Bry-Smart control		√

ALL DATA SUBJECT TO CHANGE WITHOUT NOTICE

