

STANDARD UNIT

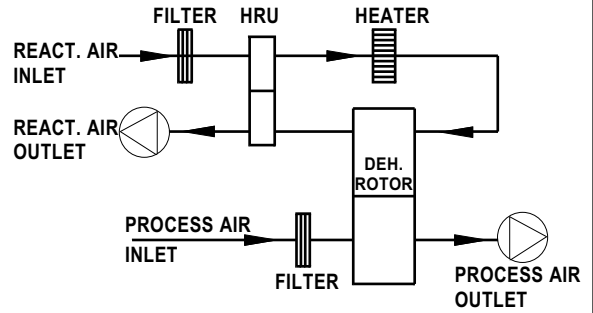

STANDARD PACKAGING OPTIONS FOR FVB Sr.

OPTION 1 : WITH PRE COOL

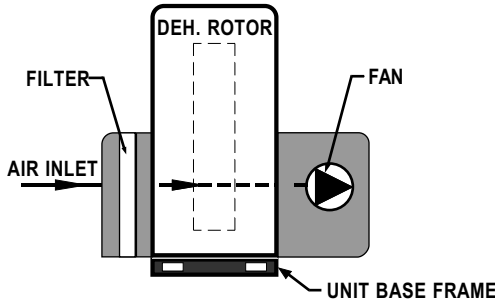
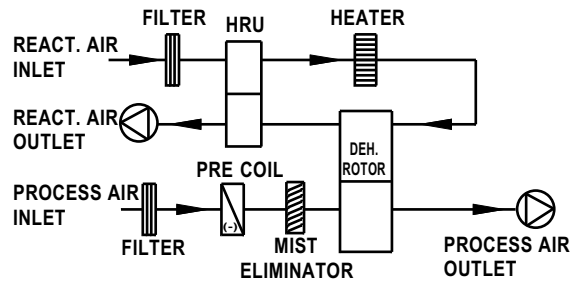
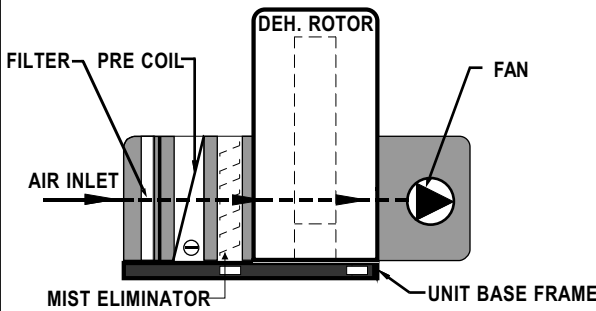

OPTION 2 : BOTH PRE COOL & AFTER COOL

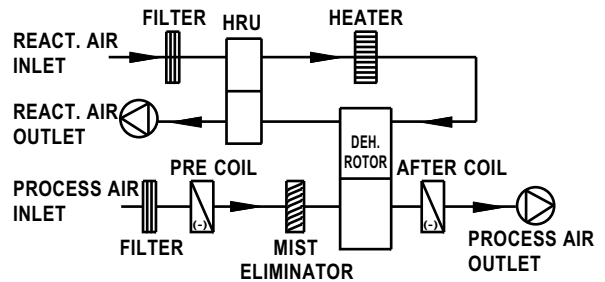
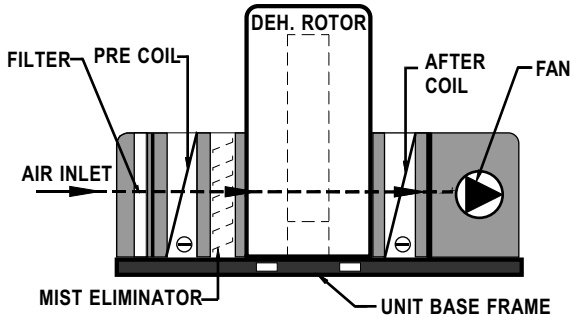

OPTION 3 : WITH ROTOR BYPASS & AFTER COOL

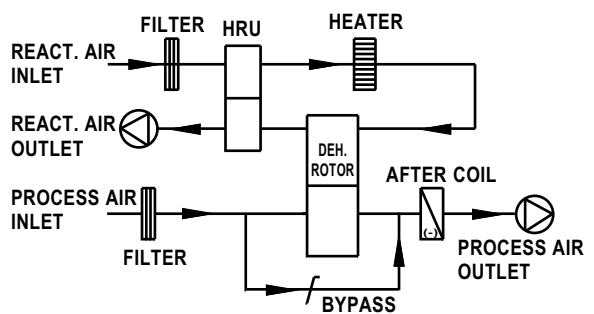
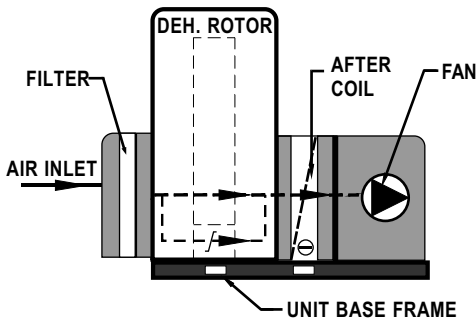

OPTION 4 : WITH MIXING BOX FOR RETURN AND FRESH AIR PRE COOL, WITH OR W/O BYPASS & AFTER COOL

